

REV	Description	DATE	BY
Ver 1	Initial Release.		

PAGE NO.	SCHEMATIC PAGE
1	TITLE PAGE
2	BLOCK
3	Z7020_PL
4	POWER LOGIC
5	Z7020_PS
6	Z7020_POWER
7	USB OTG
8	DDR3 MEMORY
9	QSPI FLASH
10	10/100/1000 ETHERNET
11	HDMI
12	Sensor: G&T,CAN
13	NAND_FLASH
14	PWR:1.0V&1.5V,VTT
15	Power 1.8V,3.3V&DCin
16	EXP CONN
17	MISC

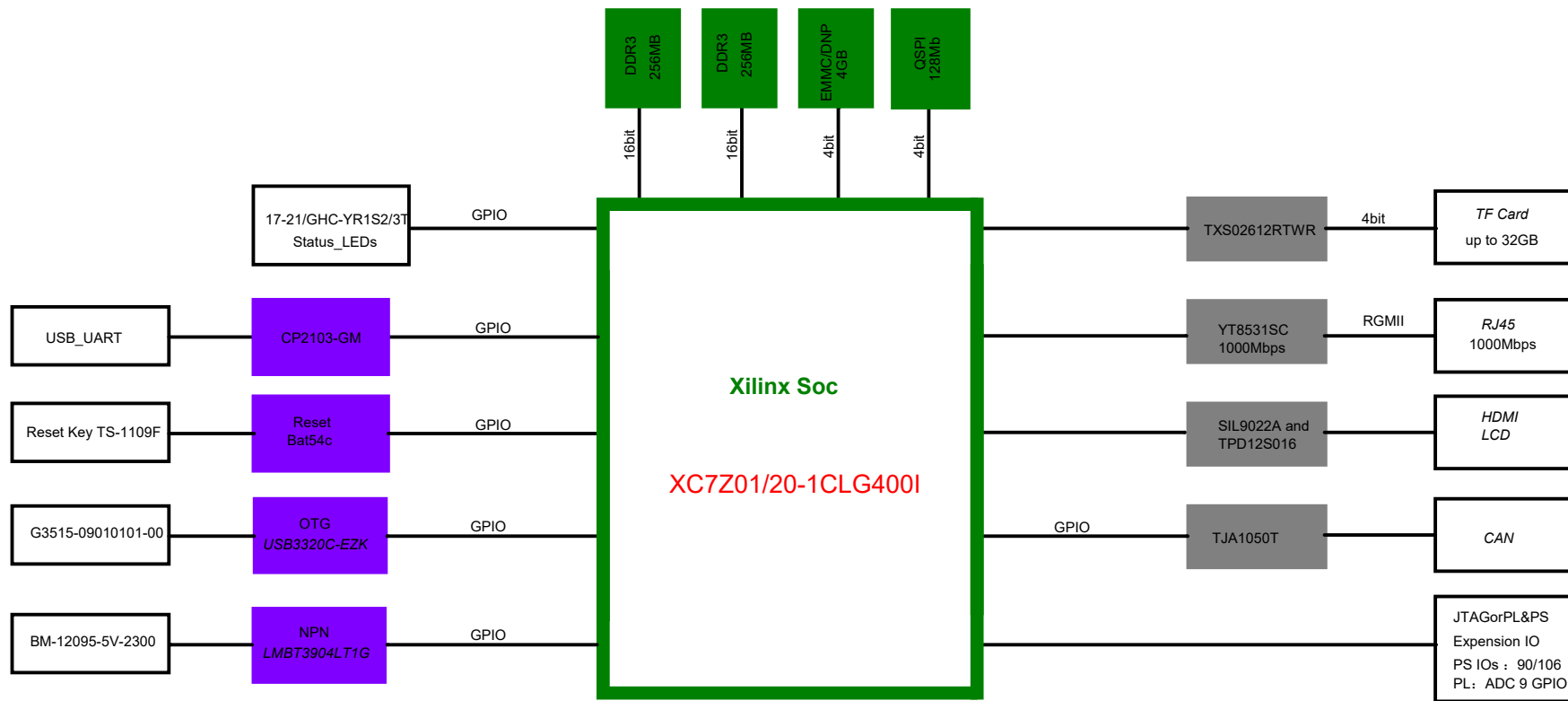

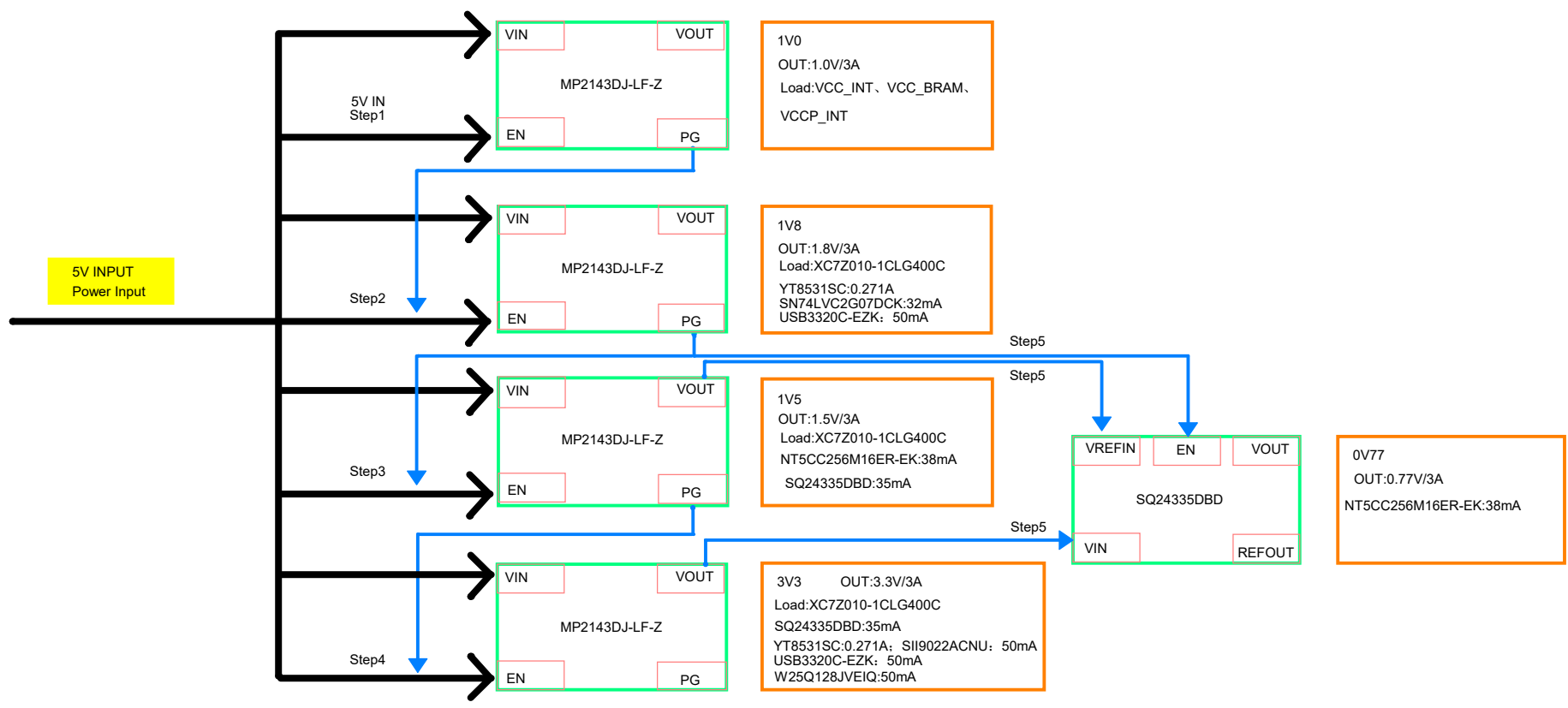

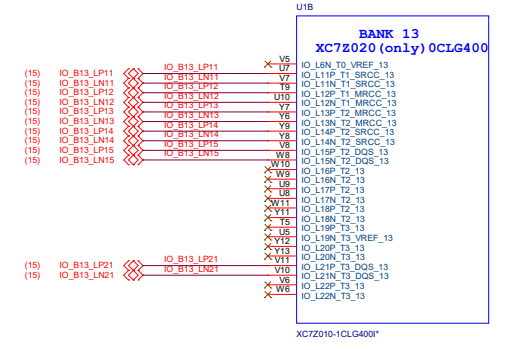
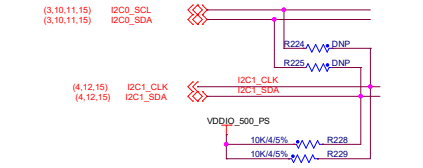
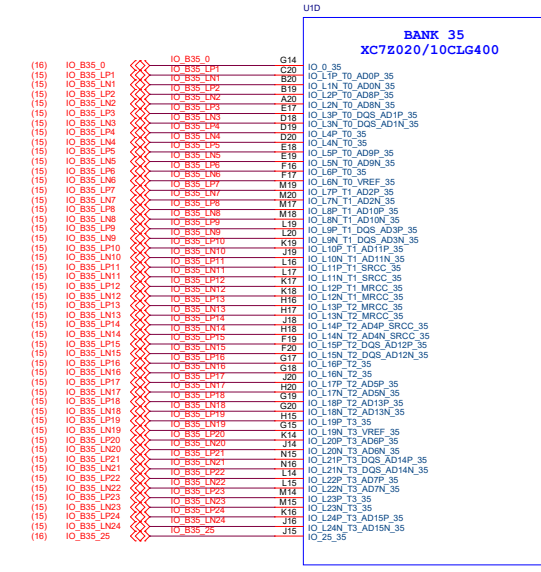
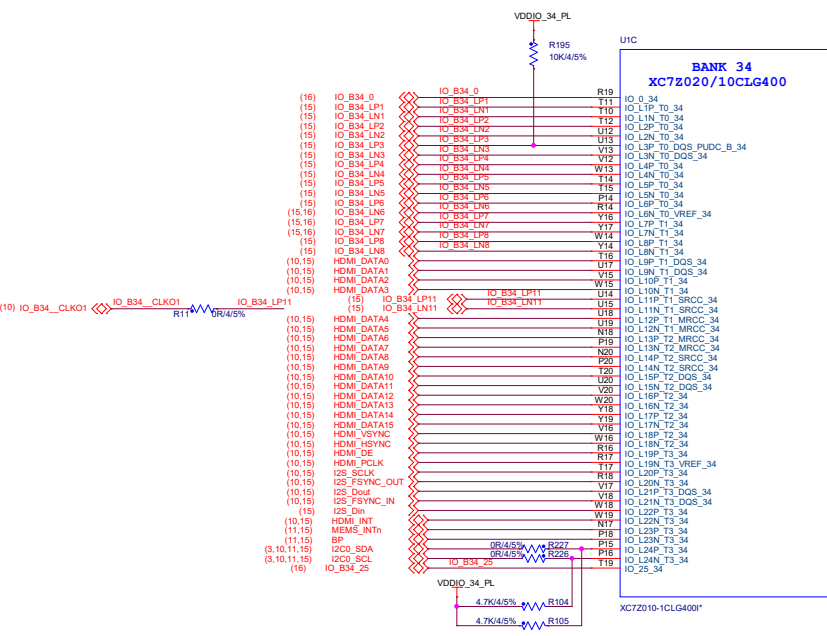
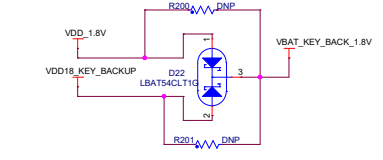
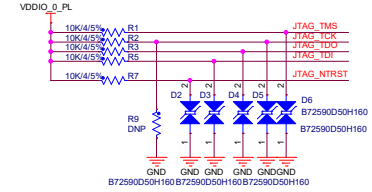
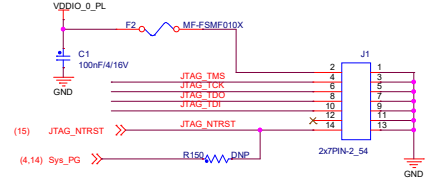
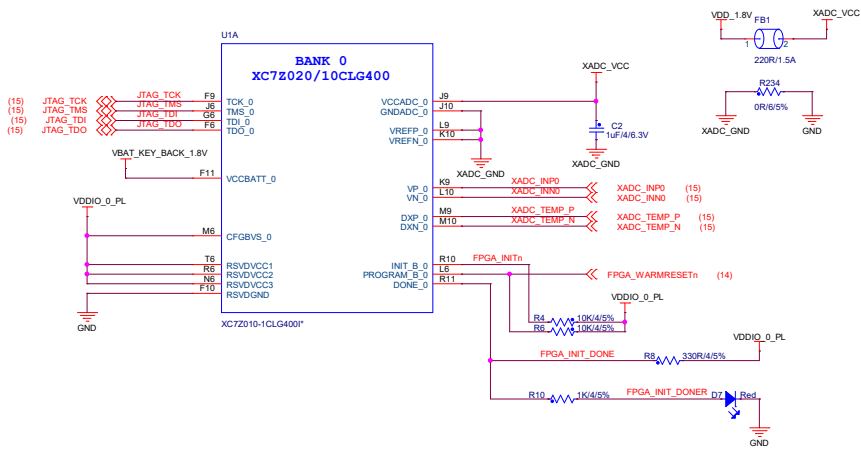

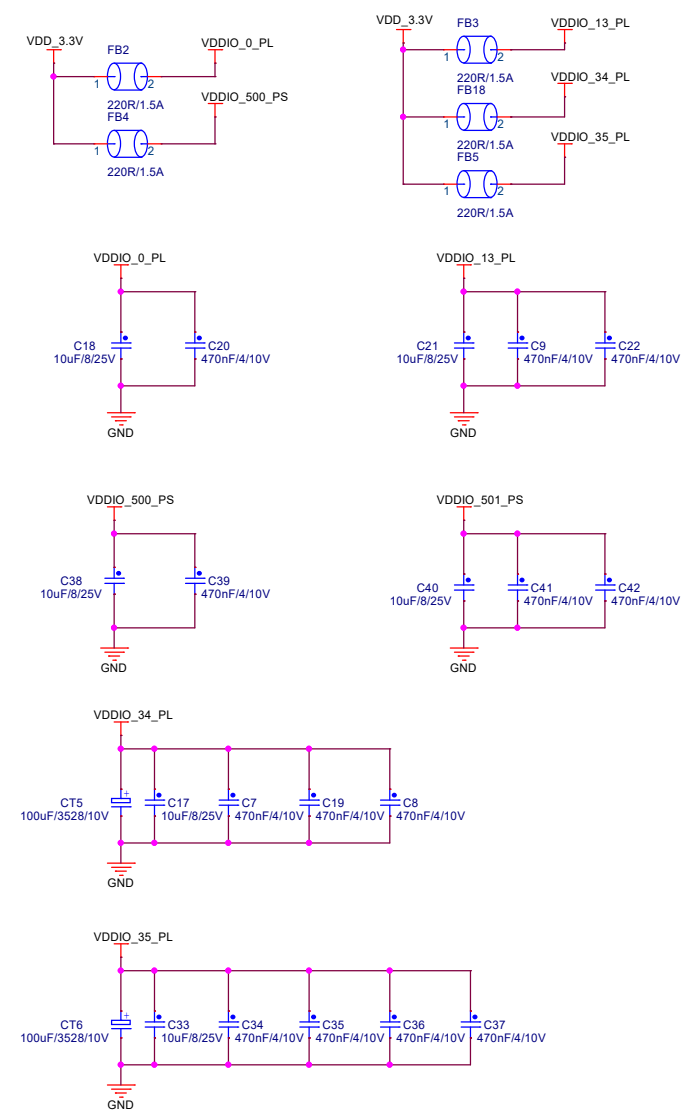
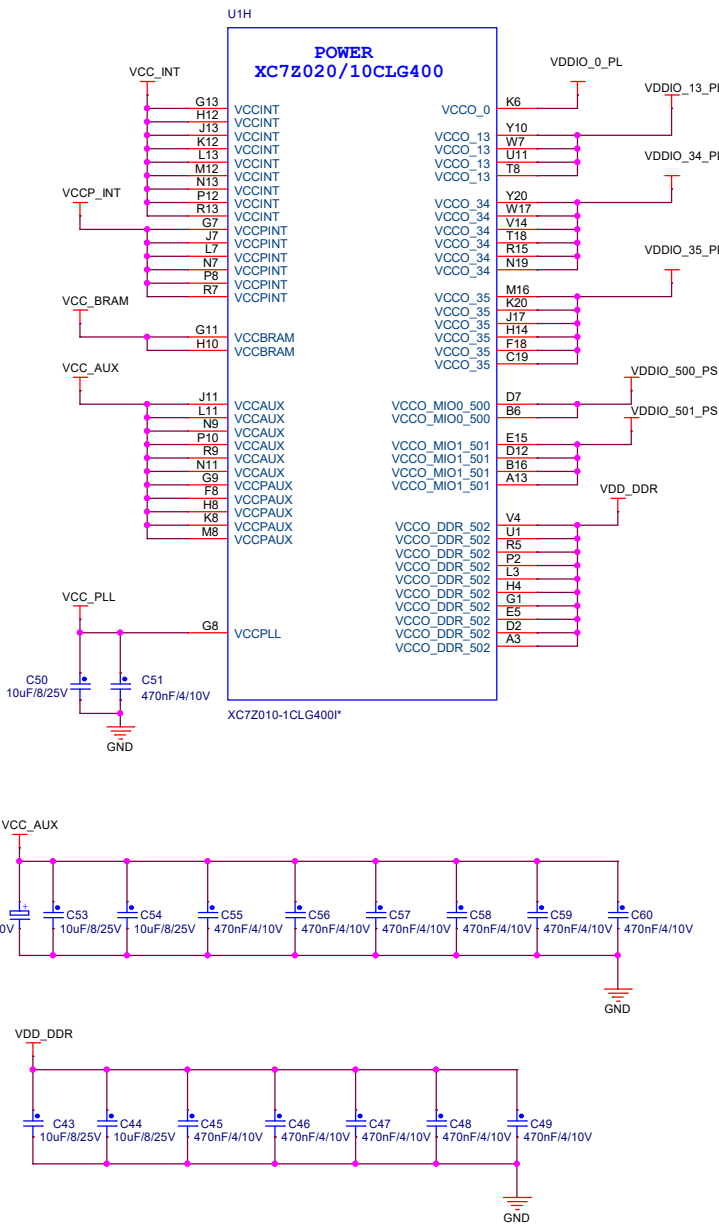
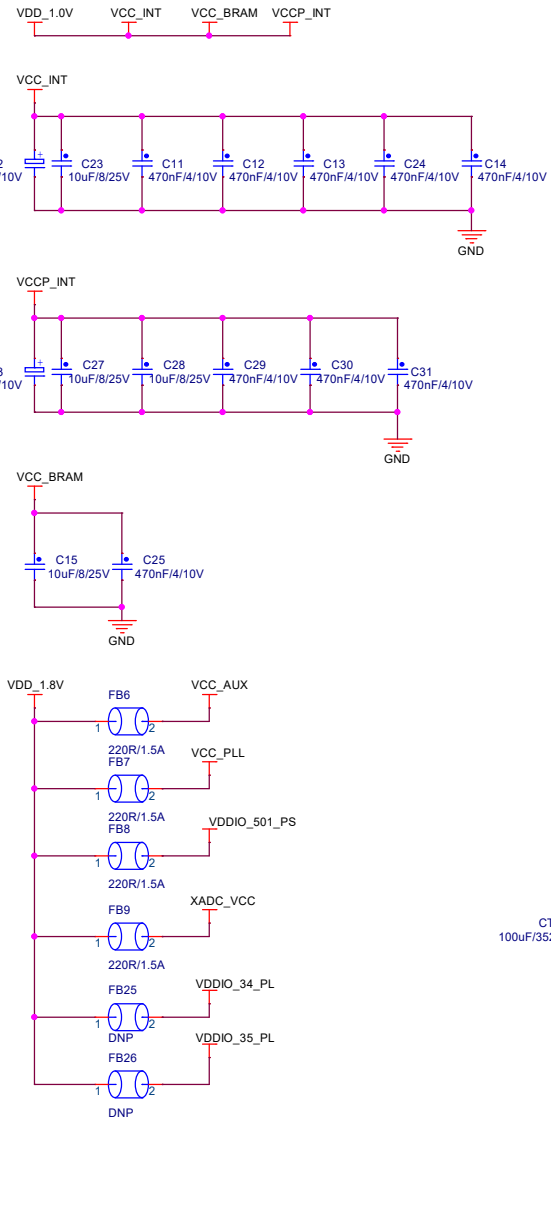

XC7Z020-1CLG400*

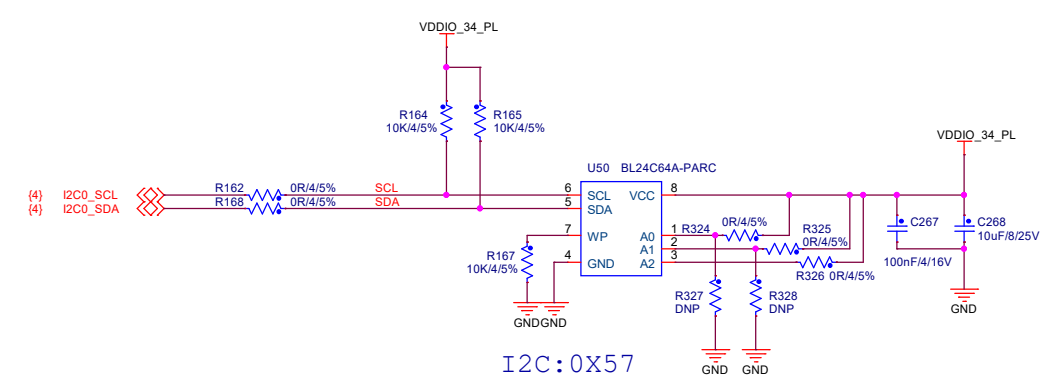
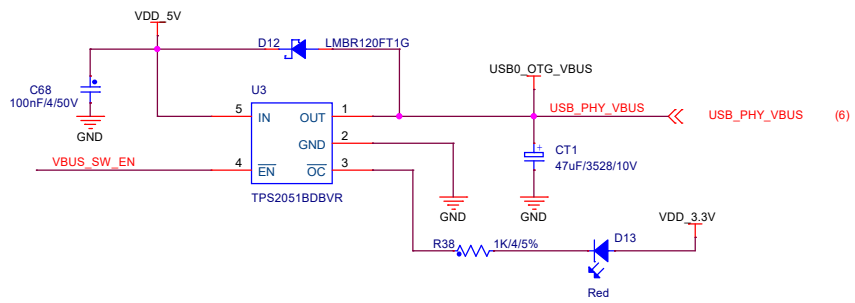
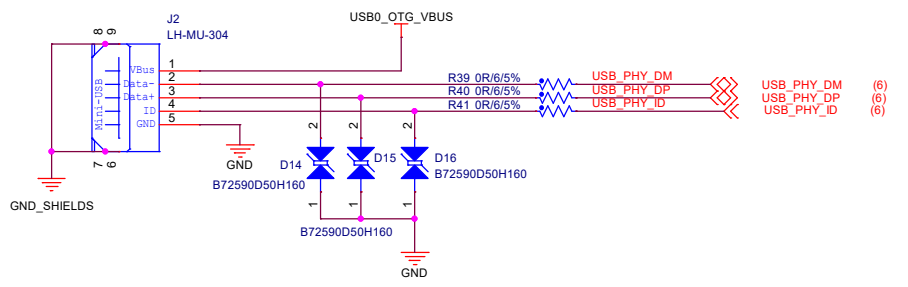
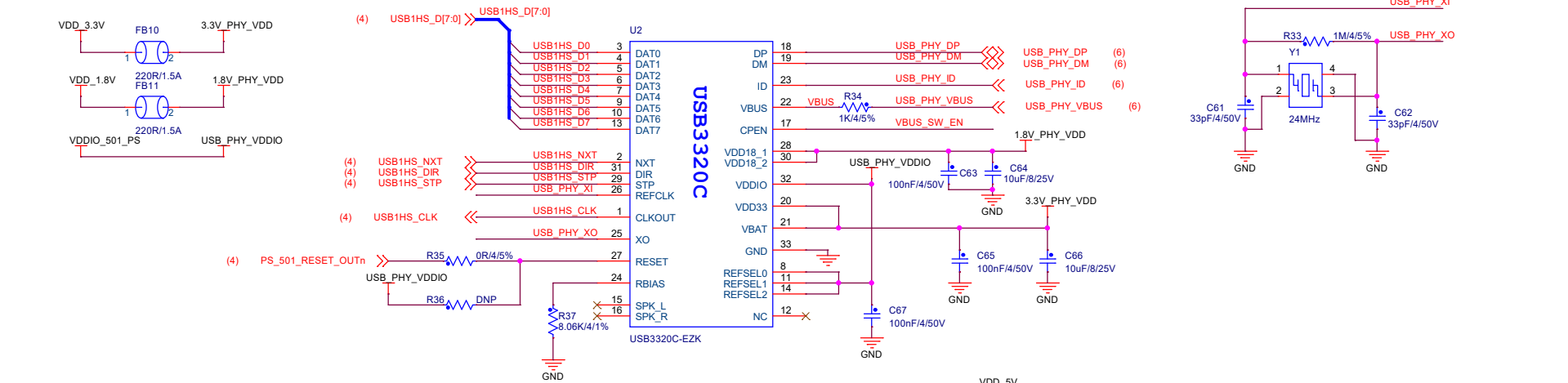



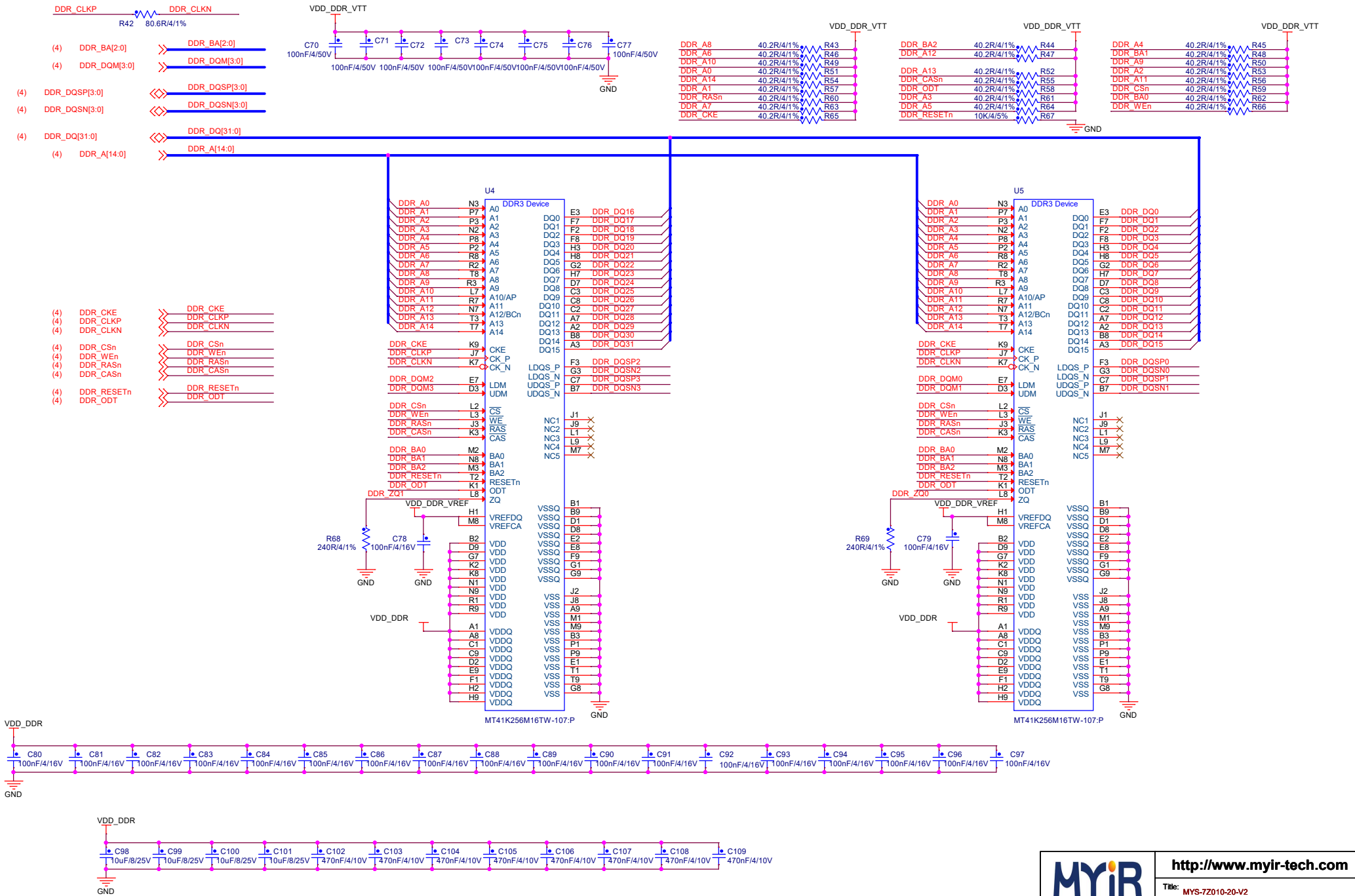

1024MB DDR3 (x32)

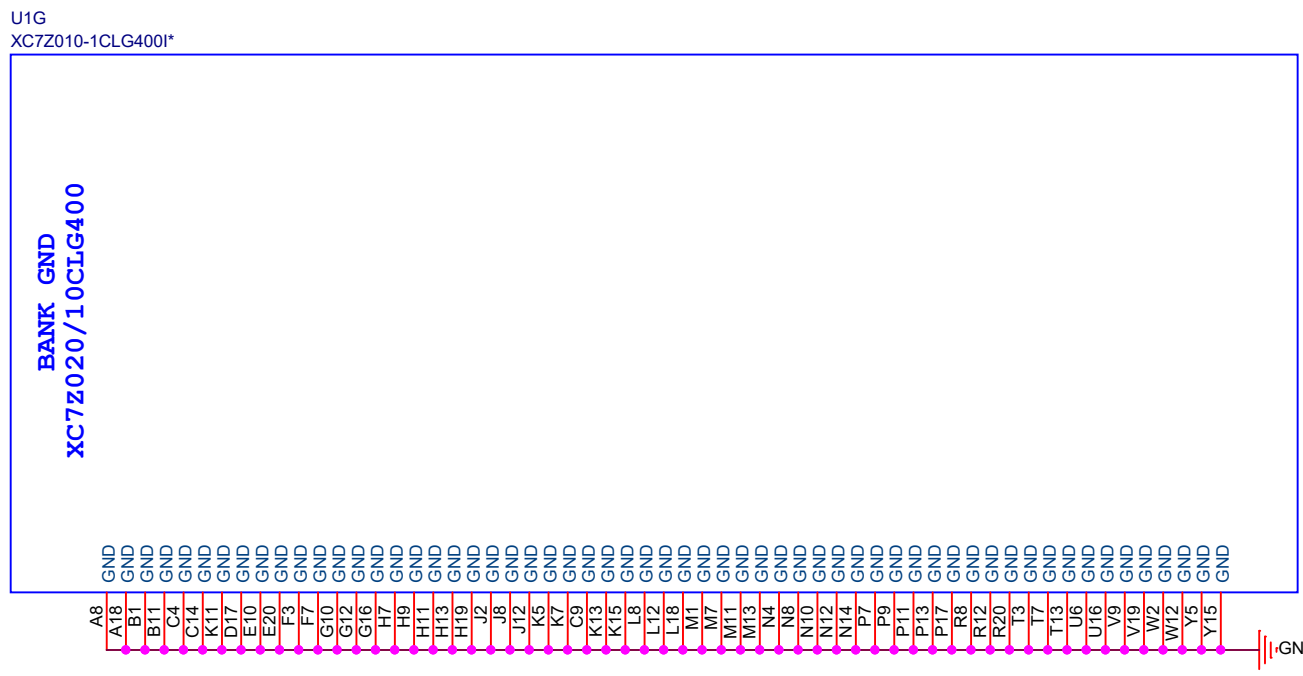
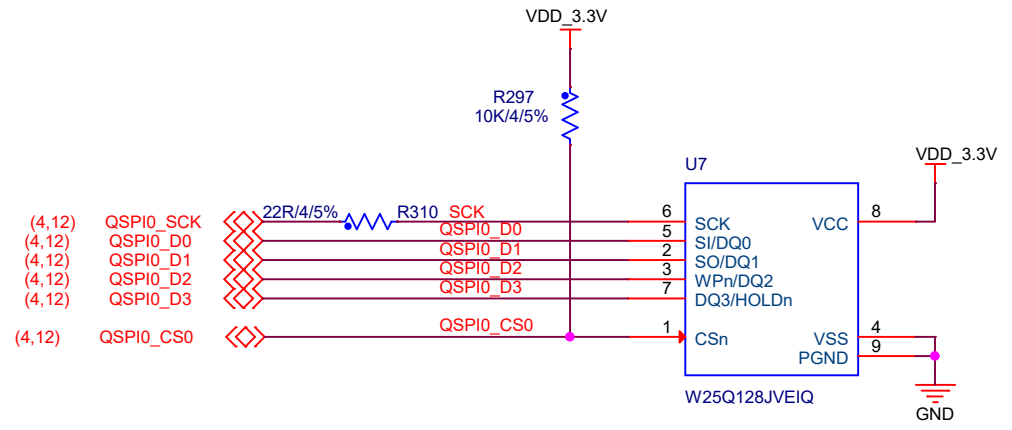
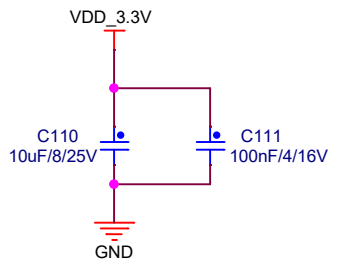

		http://www.myir-tech.com	
		Title: MYS-7Z010-20-V2	
Size: A3	Document Number: DDR3 MEMORY	Rev: V1.0	Draw By: MYIR
Date: Wednesday, September 14, 2022		Sheet: 07 of 17	



		http://www.myir-tech.com	
		Title: MYS-7Z010-20-V2	
Size: A4	Document Number: QSPI FLASH	Rev: V1.0	
Draw By: MYIR	Date: Wednesday, September 14, 2022	Sheet: 08 of 17	

INCREASE MDIO_DATA length 4000mil (shorted by R265)

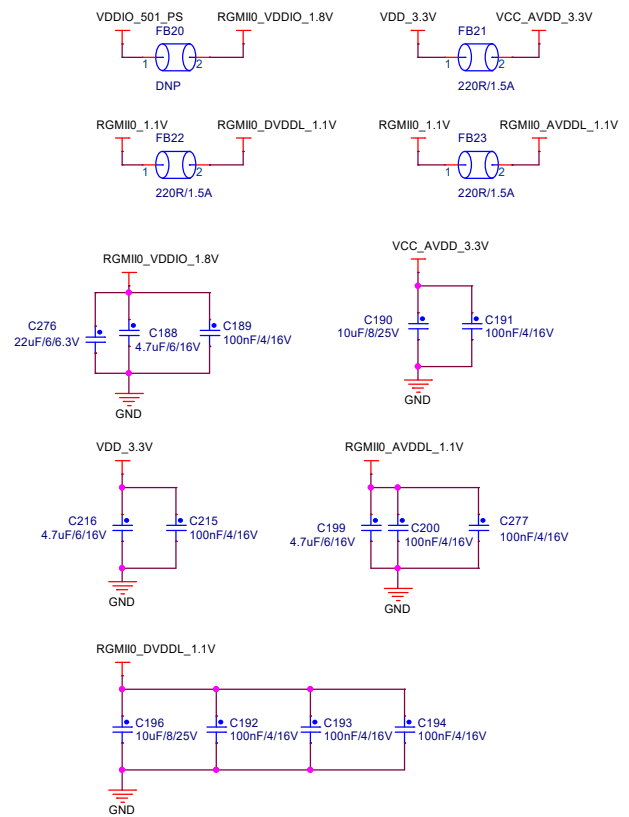
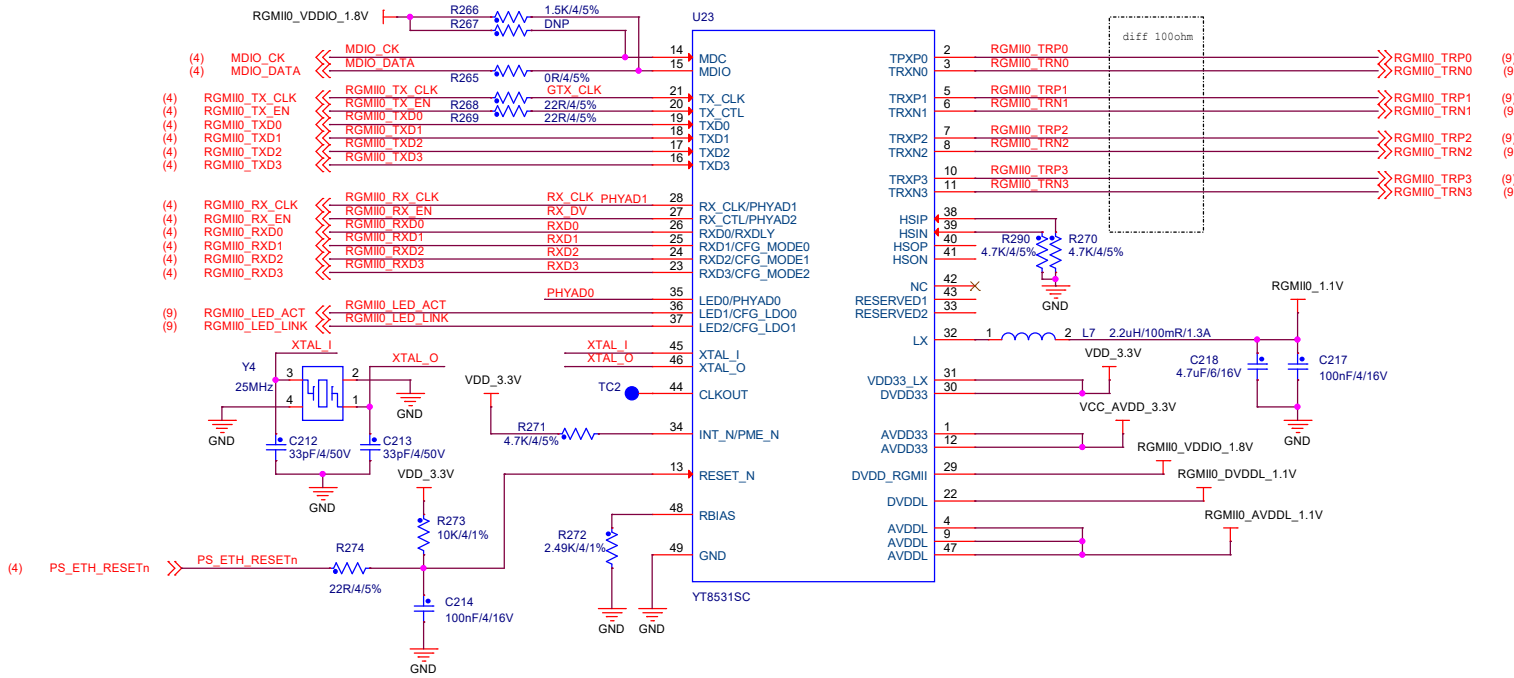

CFG_MODE0	CFG_MODE[2:0]: Operation Mode Configuration. 3'b000: UTP <-> RGMII 3'b001: FIBER <-> RGMII 3'b010: UTP/FIBER <-> RGMII (Media Auto Detection) 3'b011: UTP <-> SGMII 3'b100: SGMII (PHY side) <-> RGMII (MAC side), 3'b101: SGMII (MAC side) <-> RGMII (PHY side) 3'b110: UTP <-> FIBER (Media Conversion auto mode) 3'b111: UTP <-> FIBER (Media Conversion force mode)
CFG_MODE1	
CFG_MODE2	

CFG_LDO[1:0]	Voltage selection for RGMII I/O
2'b00	3.3V
2'b01	2.5V
2'b10 or 2'b11	1.8V

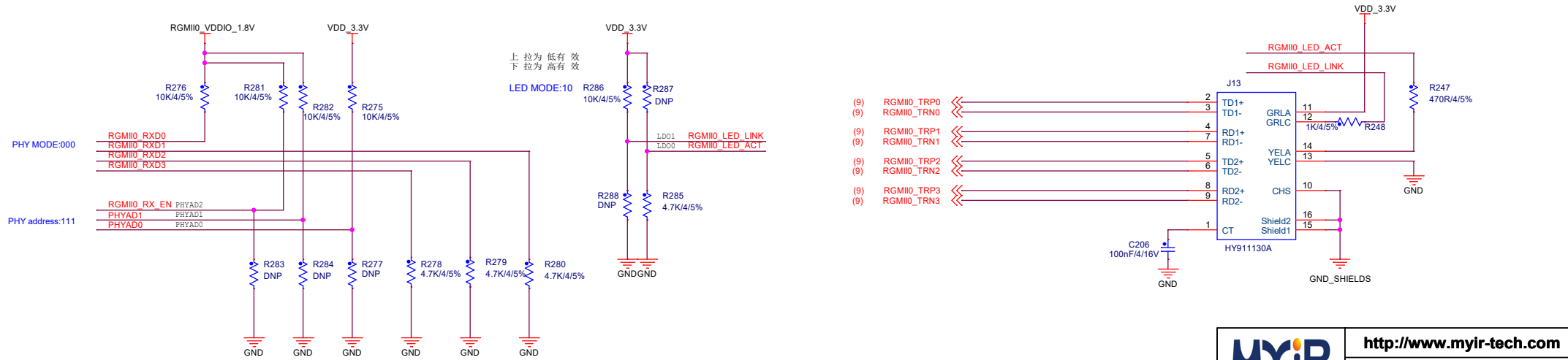

MYIR <http://www.myrir-tech.com>

Title: MYS-7Z010-20-V2

Size: A3	Document Number: 10/100/1000 Ethernet	Rev: V1.0
Draw By: MYIR	Date: Wednesday, November 09, 2022	Sheet: 09 of 17

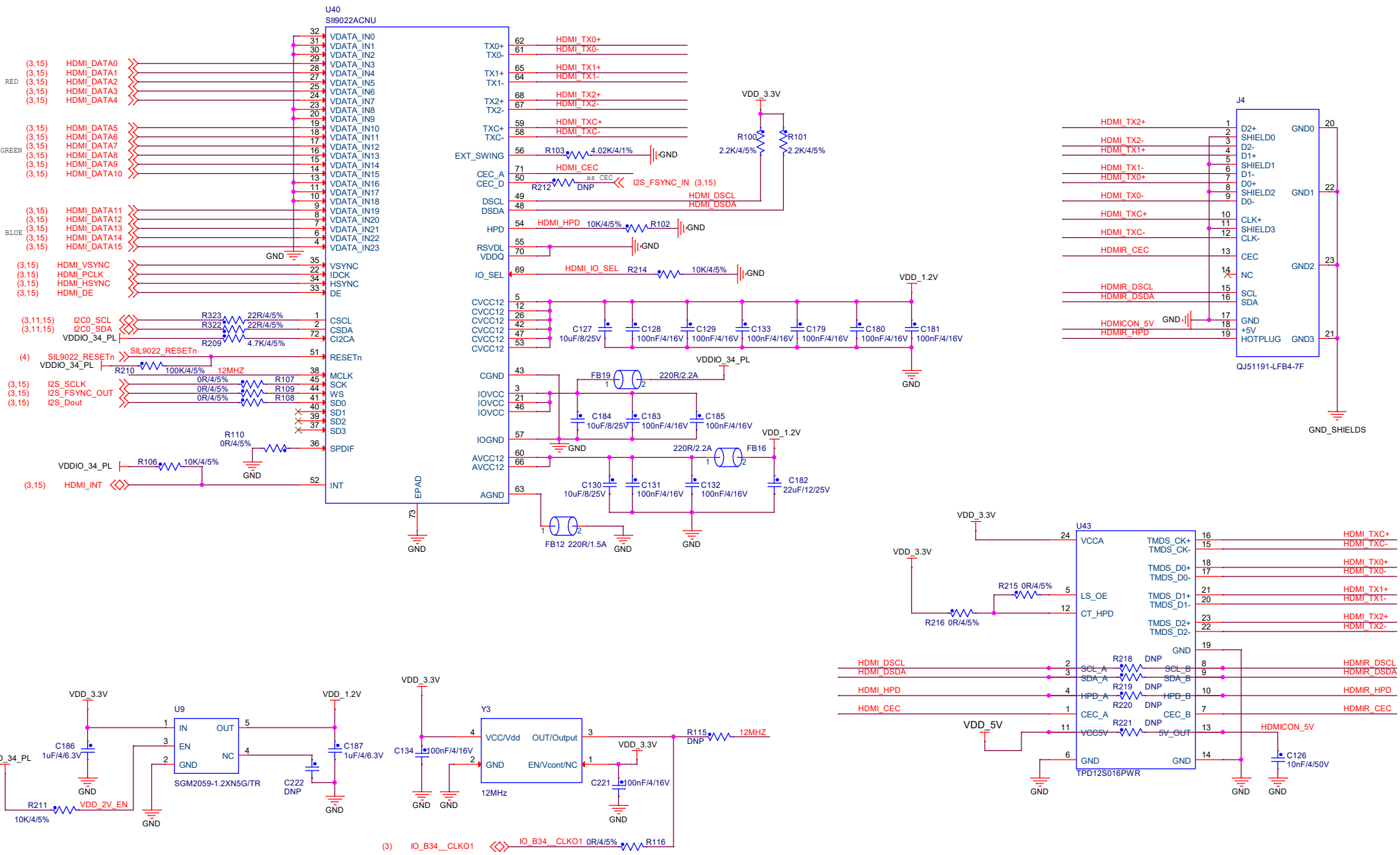

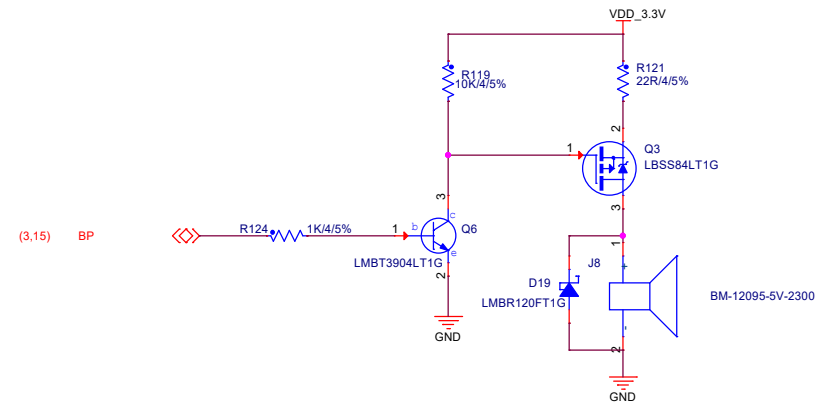
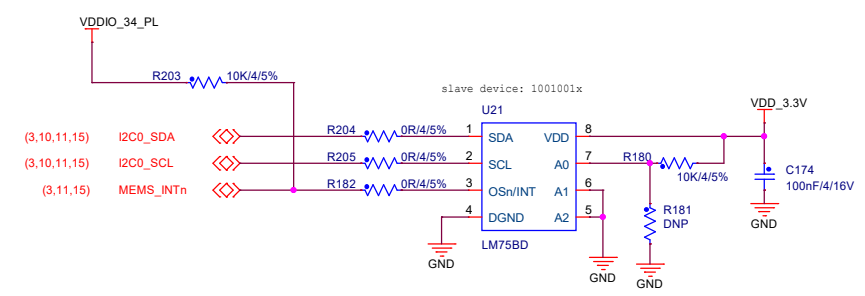
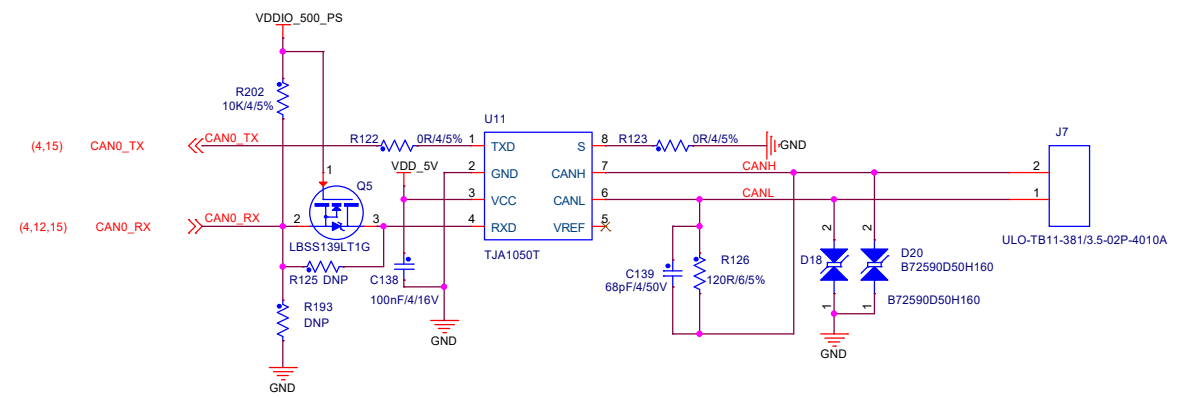
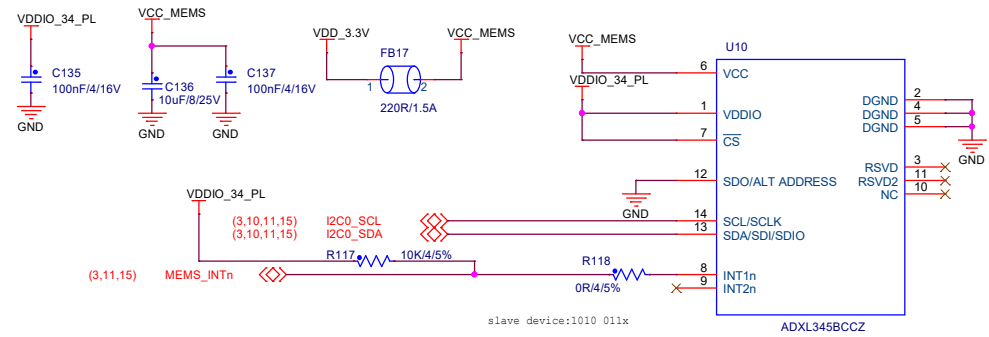

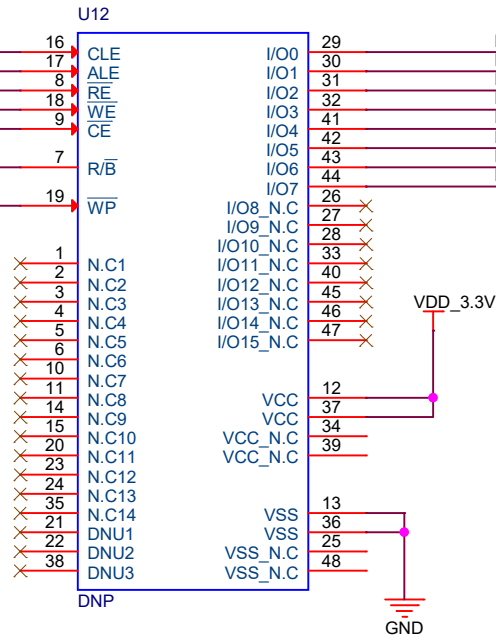
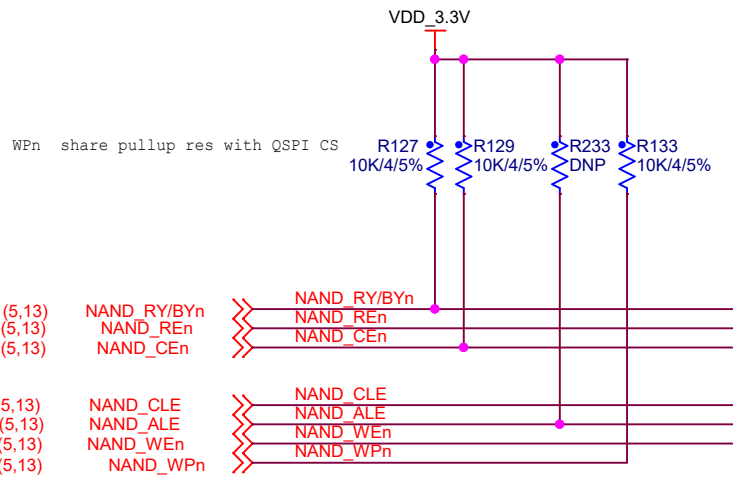
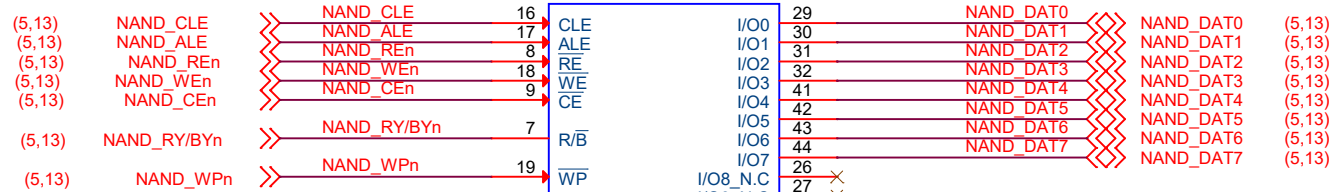
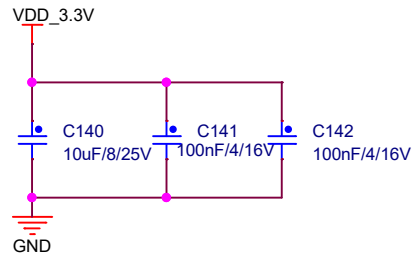

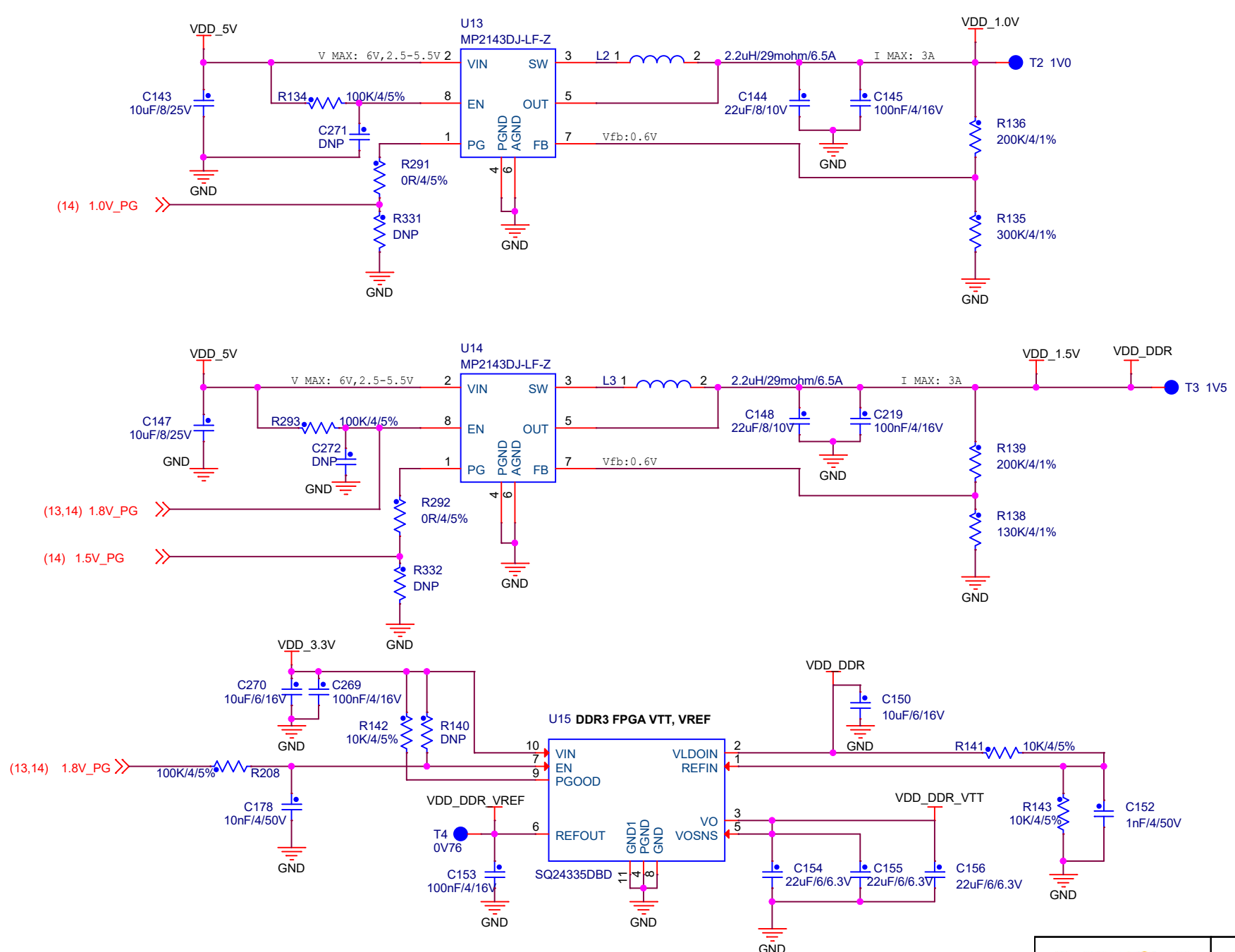

		http://www.myir-tech.com	
		Title: MYS-7Z010-20-V2	
Size:	Document Number:	Rev:	
A4	NAND_FLASH	V1.0	
Draw By: MYIR	Date: Wednesday, September 14, 2022	Sheet: 12 of 17	

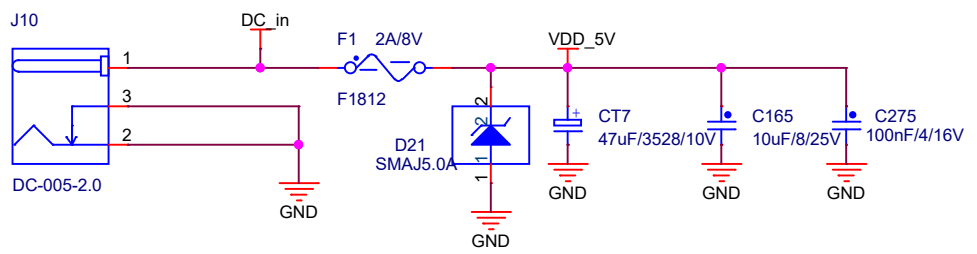
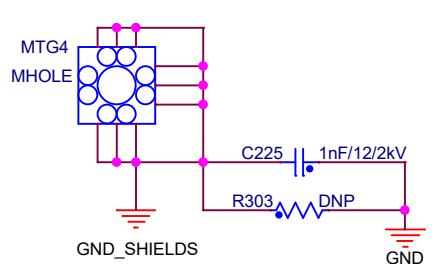
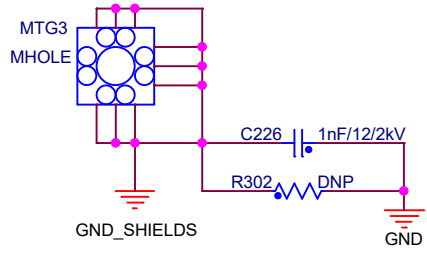
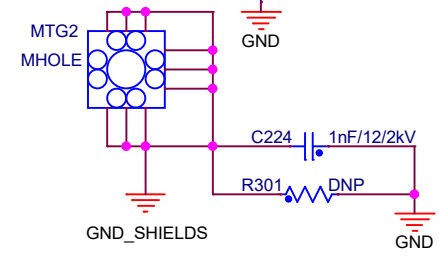
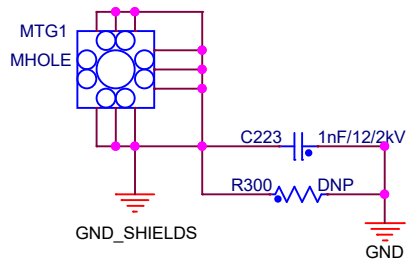
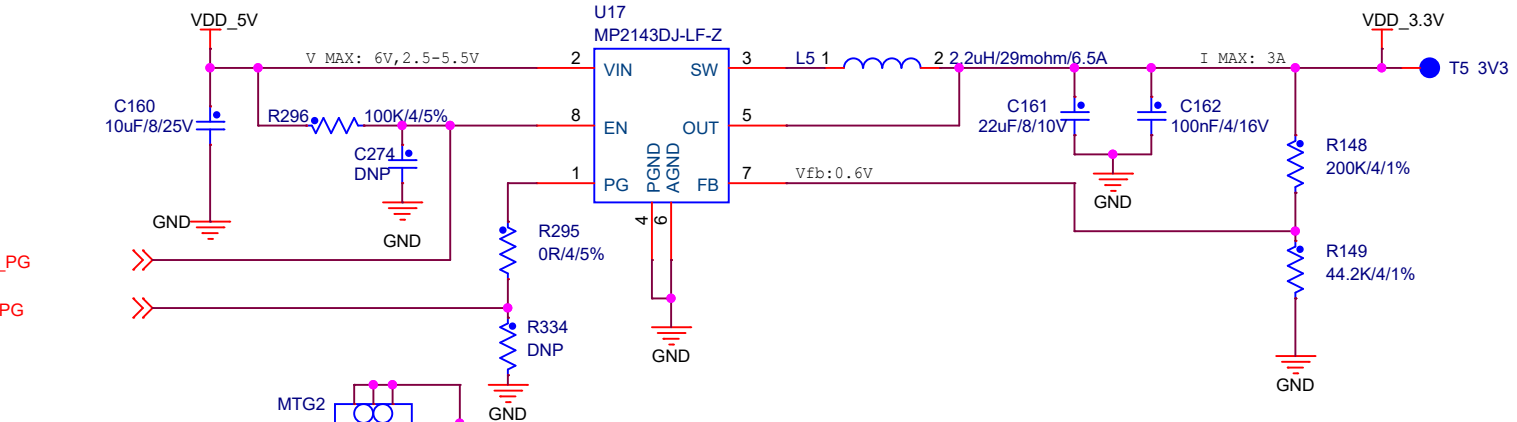
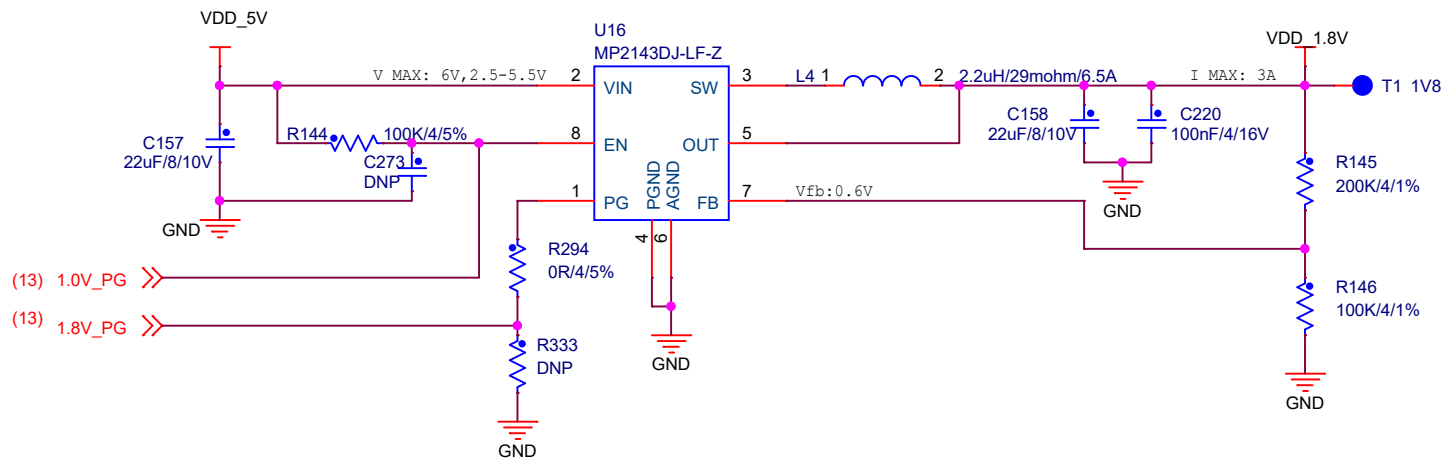

		http://www.myir-tech.com	
		Title: MYS-7Z010-20-V2	
Size: A4	Document Number: PWR:1.0V&1.5V,VTT	Rev: V1.0	
Draw By: MYIR	Date: Thursday, November 10, 2022	Sheet: 13 of 17	



		http://www.myir-tech.com	
		Title: MYS-7Z010-20-V2	
Size: A4	Document Number: Power 1.8V,3.3V&DCin		Rev: V1.0
Draw By: MYIR	Date: Friday, November 04, 2022	Sheet: 14 of 17	

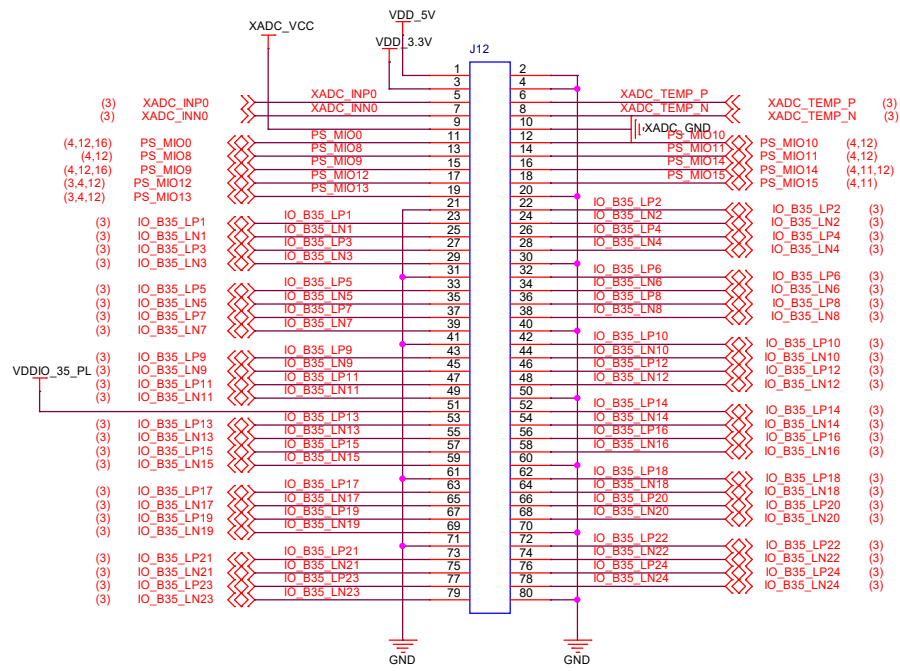
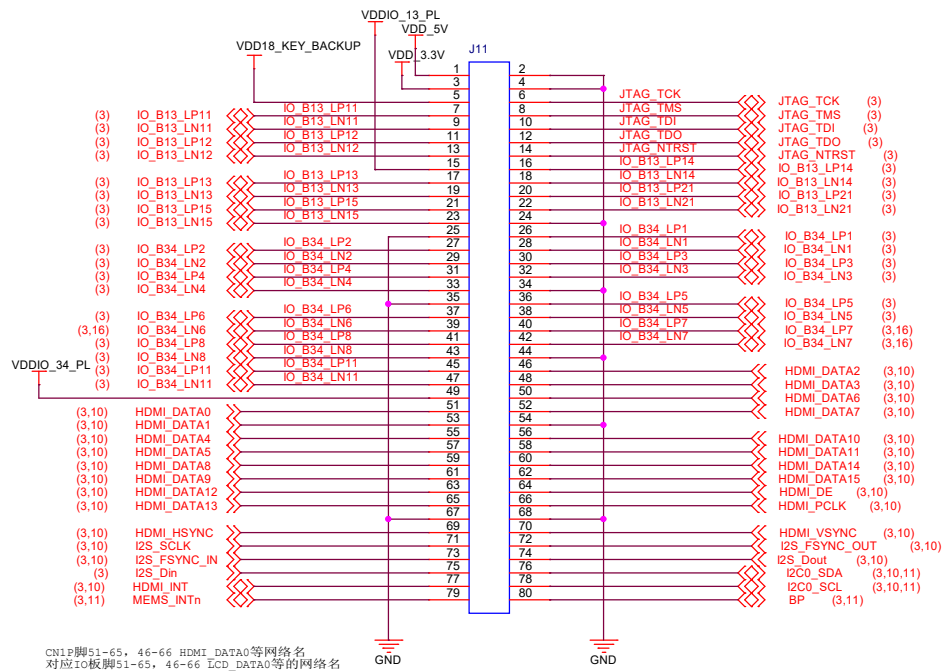

CN1P脚51-65, 46-66 HDMI_DATA0等网络名
 对应IO板脚51-65, 46-66 LCD_DATA0等的网络名

